



1111 W. 35th Street Chicago, IL 60609
 Tel: (773) 869-1111 • Fax: (773) 869-1329
 FaxBack: (773) 869-1877 • www.tripplite.com

SRX2, SRX3 and SRX4 Rack Mount Fixed And Roll-Out Shelves

CLIP NUT INSTALLATION

Clip Nuts provide mounting points for rack mount fixed and roll-out shelves.

Clip nuts have a front or screw side. Consider which way it should face for ease of access to the screw head during component installation. (figure 1)

To remove a clip nut from a mounting angle, insert a flat blade screwdriver or knife under the tab on the front and pry up, freeing the retaining ring from the mounting angle. (figure 2)

1. Select the location at which the shelf will be mounted in the enclosure assembly.
2. Snap one clip nut into the top hole of the selected location.
 (note: When mounting a roll-out shelf, insert a 10-32 screw partially into each clip nut.)
 If the weight load will exceed 75 lbs. on a roll-out shelf, use four clip nuts and screws in each of the brackets. It will be necessary to select a four-hole grouping that matches the mounting holes in the brackets. The center two holes will measure 1/2" apart.
 Two screws per bracket, one at the front and one at the rear, is sufficient if the weight load will be less than 75 lbs.
3. Measure from the bottom of the Mounting Angle to the top clip nut. Assemble clip nuts onto the three other rails at the measured height.

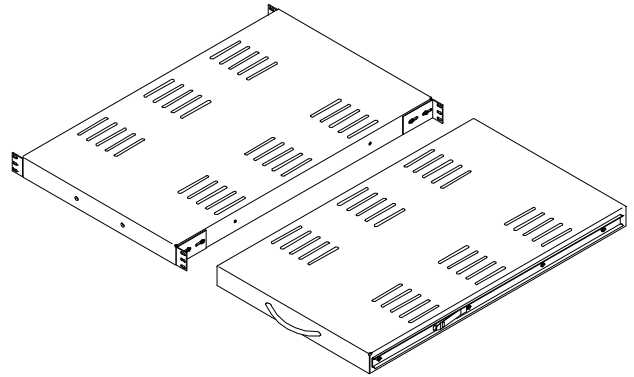

Rack Mount Fixed And Roll-Out Shelves

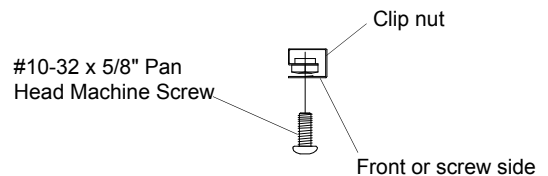

Figure 1

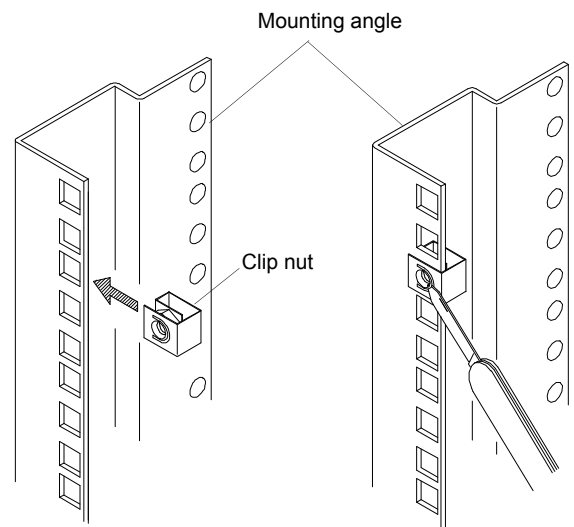

Figure 2



1111 W. 35th Street Chicago, IL 60609
 Tel: (773) 869-1111 • Fax: (773) 869-1329
 FaxBack: (773) 869-1877 • www.tripplite.com

SmartRack™
 Network Enclosure

SRX2 and SRX3 Rack Mount Fixed Shelves

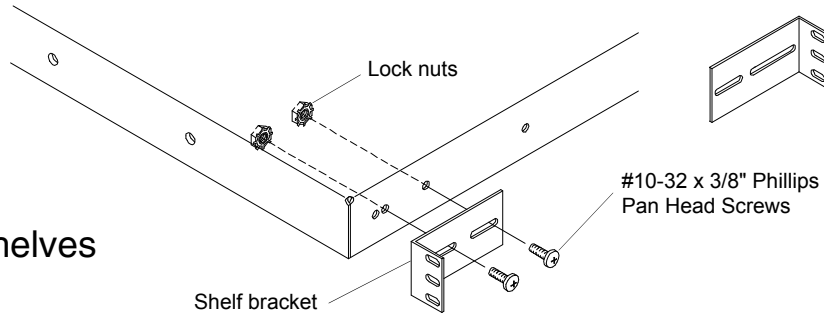

Figure 3

FIXED SHELF INSTALLATION

1. Install the front and rear shelf brackets as shown on both the left hand and on the right hand side of the shelf. (figure 3)
2. Align the shelf with the previously installed clip nuts and attach the shelf with the 10-32 screws that are provided. Once the screws have started in all four corners, tighten all of the screws.

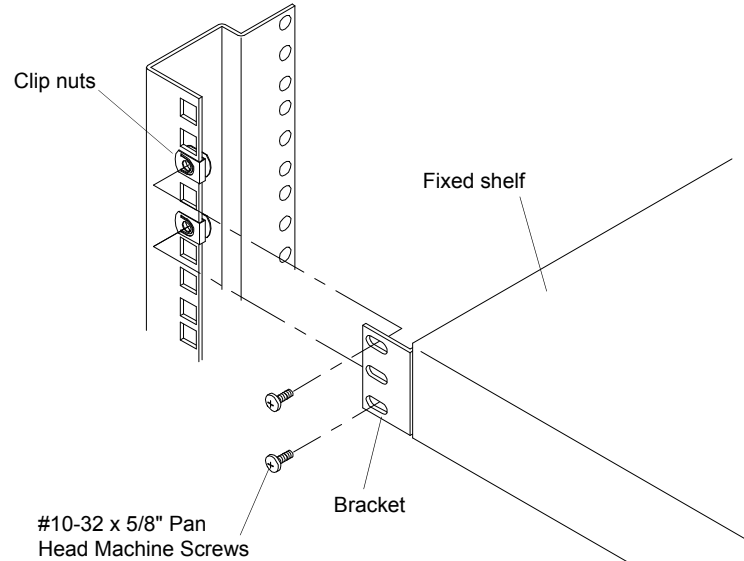

Figure 4

FIXED SHELF ADJUSTMENT

1. To adjust the Fixed Shelf, loosen the bracket screws, move the brackets, then re-tighten the screws. (figure 5)

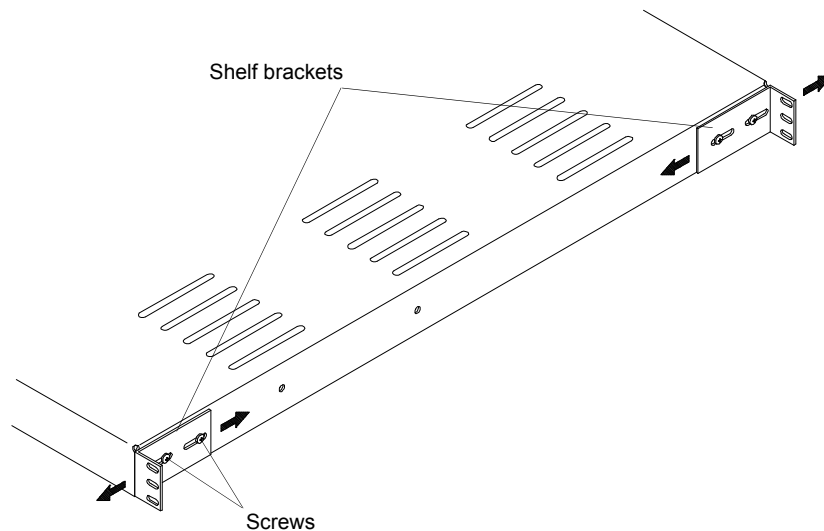
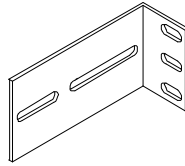

Figure 5



1111 W. 35th Street Chicago, IL 60609
 Tel: (773) 869-1111 • Fax: (773) 869-1329
 FaxBack: (773) 869-1877 • www.tripplite.com

SmartRackSM
 Network Enclosure



Stationary Shelf Bracket

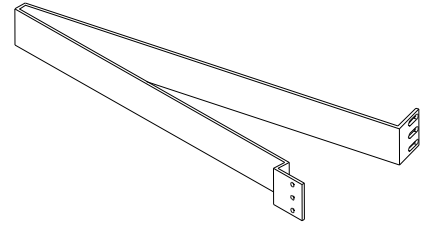

Cable Management Arm
 (included with SRX4 only)

SRX2, SRX3 and SRX4 Rack Mount Fixed And Roll-Out Shelves

Required Tools:

Phillips Head Screwdriver
 3/8" Nut Driver (or Socket Wrench)
 11/32" Nut Driver (or Socket Wrench)



#8-32 x 3/8" Phillips Pan
 Head Machine Screw

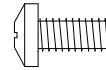

#8-32 Hex Lock Nut



Fasteners That May Be Required:



#10-32 x 5/8" Phillips
 Machine Screw

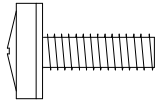

#10-32 Keps Locking Nut

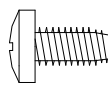

#10-32 Keps Locking Nut



#10-32 Clip Nut

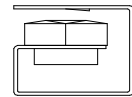
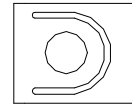

SRX2 & SRX3 Parts List		
Item	Description	Qty.
1	#10-32 x 5/8" Screw	12
2	#10-32 x 3/8" Screw	8
3	#10-32 Keps Locking Nut	8
4	#10-32 Clip Nut	12
5	Stationary Shelf Bracket	4

SRX4 Parts List		
Item	Description	Qty.
1	#10-32 x 5/8 Screw	16
2	#10-32 Clip Nut	16
3	Slide Bracket	2
4	Warning Label	1
5	#8-32 x 3/8 Screw	2
6	#8-32 Keps Locking Nut	2
7	Cable Management Arm	1